

- Low profile case, module depth only 59,5mm
- Suitable for mounting in domestic installation panels
- Low output ripples and spikes
- Fully compliance to ECO-Standard
- Suitable for household appliance
- Safety class II product
- UL 1310 class II, NEC class 2 compliance
- UL 508 listed
- Universal input range 85 to 264 VAC
- Operating temperature range: -25°C to +70°C max.
- Adjustable output voltage
- Short circuit and overload protection
- DC-OK indicator



This new DIN-Rail mounting power supplies are designed for industrial and residential applications. They are lower cost than the existing TBL range, with similar electrical specifications. Additionally, they fully comply to the new standby power and efficiency requirements (ECO Standard). They are intended for connecting as class II devices, so the safety earth connection is not required. They are mountable in flat racks due to their small dimensions in depth. Their dimensions comply to the DIN 43 880 standard.

Models				
Order Code	Output Power (max.)	Output Voltage* (nom.)(adjustable)	Output Current (max.)	Efficiency (typ.)
TBLC 06-105	6 W	5.0 VDC	1.2 A	74 %
TBLC 06-112	6 W	12 VDC	0.5 A	81 %
TBLC 06-124	6 W	24 VDC	0.25 A	79 %
TBLC 15-105	12 W	5.0 VDC	2.4 A	81 %
TBLC 15-112	15 W	12 VDC	1.25 A	85 %
TBLC 15-124	15 W	24 VDC	0.63 A	85 %
TBLC 25-105	20 W	5.0 VDC	4.0 A	82 %
TBLC 25-112	24 W	12 VDC	2.0 A	86 %
TBLC 25-124	25 W	24 VDC	1.05 A	87 %
TBLC 50-112	48 W	12 VDC	4.0 A	88 %
TBLC 50-124	50 W	24 VDC	2.1 A	89 %
TBLC 75-112	72 W	12 VDC	6.0 A	89 %
TBLC 75-124	75 W	24 VDC	3.1 A	89 %
TBLC 90-112	90 W	12 VDC	7.5 A	90 %
TBLC 90-124	90 W	24 VDC	3.75 A	90 %

Input Specifications

Input voltage	– nominal ranges – effective ranges	100 – 240 VAC; 50/60 Hz 85 – 264 VAC; 47-63 Hz (below 100 VAC a derating of 2%/V is required)
Input voltage frequency		47 – 63 Hz
No load power consumption	6–50 W models: 75–90 W models:	> 0.3 W > 0.5 W
Harmonic limits		EN 61000-3-2, class A
Leakage current		0.25 mA / 0.35 mA max.
Inrush current	6–50 W models: 75–90 W models:	15/30 A (115/230 VAC) 25/50 A (115/230 VAC)

Output Specifications

Output voltage / current	5 VDC models: 12 VDC models: 24 VDC models:	5.0 – 5.5 VDC* 12.0 – 16.0 VDC* 24.0 – 28.0 VDC*
Regulation	– Input variation – Load variation (10–90 %)	0.3 % max. 0.3 % max.
Hold-up time		60 ms min. (at 230 VAC) 15 ms typ. (at 115 VAC)
Start-up	– Start up behaviour – Start up time	TBLC 075-112 and 090-112: other models: 0-75 % constant current load 0-100 % constant current load 1 s max.
Ripple and Noise (20MHz bandwidth)		50 mVp-p max.
Current limit (continuous)		105 – 130 % of I _{out} nom., constant current
Short circuit current		70 – 200 % of I _{out} nom. (typ.), foldback
Output overvoltage protection		150 % of V _{out} nom. (typ.)
DC OK signal	– trigger threshold ON	> 95 % of the set voltage

General Specifications

Operating temperature		–25°C to +70°C max. derating above +55°C : 2.5%/K
Storage temperature		–40°C to +85°C max.
Temperature coefficient		0.02 %/K
Cooling		convection cooling, no internal fan
Pollution degree		2
Humidity (non condensing)		5–95 % rel. H max.
Altitude during operation		5000 m max.
Isolation	– I/O isolation	3000 VAC (4242 VDC)
Class of protection		safety class II
Degree of protection		IP 20 (IEC/EN 60529)

* Output voltage can be adjusted as indicated. However, output power has to be maintained at nominal value. This means the output nominal current has to be reduced in accordance with the increase of output voltage.

General Specifications (continued)

Safety standards	<ul style="list-style-type: none"> – Information technology equipment – Household applications – Safety of machinery – Safety for power electronic converter systems – Industrial control equipment – Class II Power units – NEC class 2 – Electronic equipment for power installation – Safety of transformers – Certification documents (pending) 	IEC/EN 60950-1, UL 60950-1 IEC/EN 60335-1 EN 60204 IEC/EN 62477 UL 508 UL 1310 UL 1310 (except TBLC 75-112 and 90-112) EN 50178 EN 61558-2-8, EN 61558-2-16 www.tracopower.com/overview/tbdc
Electromagnetic compatibility (EMC), Emissions	<ul style="list-style-type: none"> – Conducted RI suppression on input – Radiated RI suppression – Harmonic current emissions 	EN 61000-6-3, EN 61204-3 EN 55022 class B, EN 55022 class B, IEC 61000-3-2 class A
Electromagnetic compatibility (EMC), Immunity	<ul style="list-style-type: none"> – Electrostatic discharge (ESD) – Radiated RF field immunity – Electrical fast transient / burst immunity – Surge immunity – Immunity to conducted RF disturbances – Power frequency field immunity – Mains voltage dips and interruptions 	EN 61000-6-2, EN 61204-3 IEC/EN 61000-4-2 4 kV/8 kV criteria B IEC/EN 61000-4-3 10 V/m criteria A IEC/EN 61000-4-4 2 kV criteria B IEC/EN 61000-4-5 1 kV/2 kV criteria B IEC/EN 61000-4-6 10 V criteria A IEC/EN 61000-4-8 30 A/m criteria A IEC/EN 61000-4-11 0% / 20ms 40% / 200ms 70% / 500ms
Environment	<ul style="list-style-type: none"> – Vibration acc. IEC 60068-2-6 – Shock acc. IEC 60068-2-27 	3 axis, 2g sine sweep, 10 – 55 Hz, 11 Oct/min 3 axis, 20g half sine, 11 ms
Enclosure material		V2 rated plastic
Mounting	– DIN-rail mounting	for DIN-rails as per EN 50022-35×15/7.5 (snap-on with self-locking spring) (included)
Environmental compliance	<ul style="list-style-type: none"> – Reach – RoHS 	www.tracopower.com/products/reach-declaration.pdf RoHS directive 2011/65/EU
Connection		screw terminal with combi-type screwheads for wire size 0.5 – 2.5mm ²

Function Specification

Block Diagram

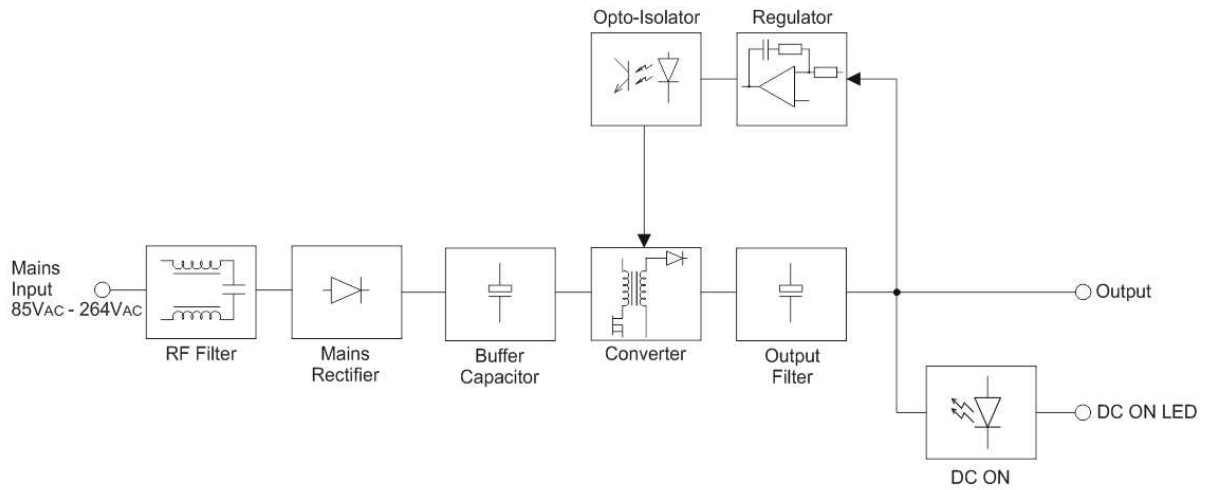

Current Limit Characteristic

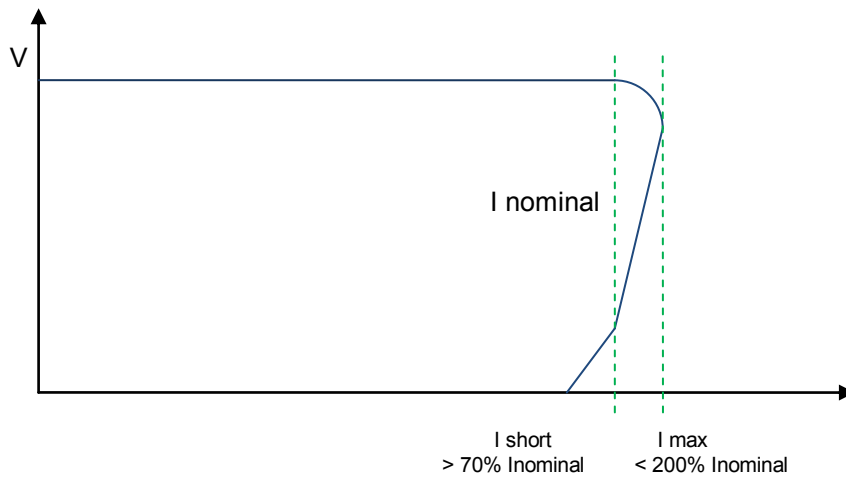

The load characteristic is designed to accomplish reliable start-up of devices requiring full current at reduced output DC voltage. The maximum current will not exceed 200% of the nominal or 8A, whilst the output power will always be less than 100W for normal and overload operation with nominal output voltages (except TBLC 90-112).

Note: All 6W models (TBLC 06-xxx) implement a pulsing power characteristic when in overload or short circuit conditions

All specifications valid at nominal input voltage, full load and +25°C after warm-up time unless otherwise stated.

Outline Dimensions

Model	Width (A) mm	Weight g (oz)
TBLC 006	18	60
TBLC 015	27	80
TBLC 025	36	110
TBLC 050	54	180
TBLC 075	72	220
TBLC 090	90	280

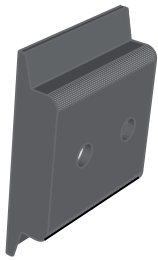
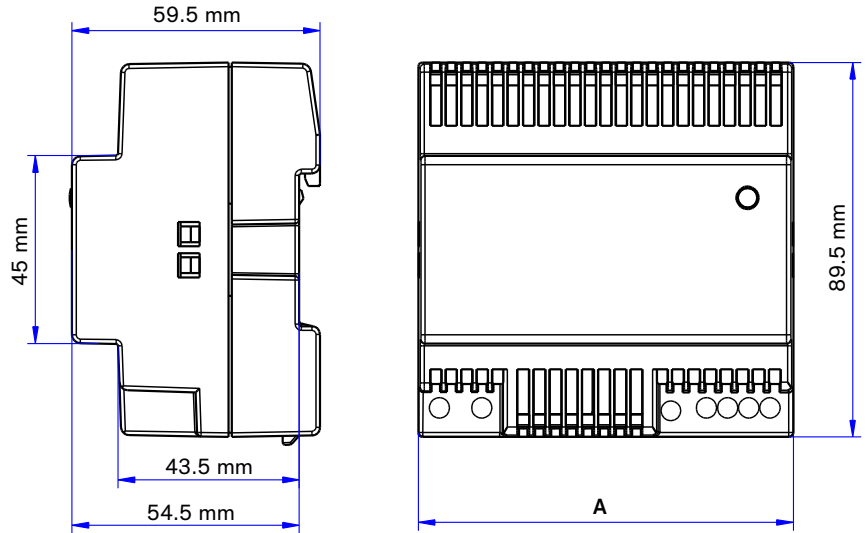

Wall Mounting Bracket

Instead of on a DIN-rail, the modules can also be mounted on a chassis or wall with help of a mounting bracket which is supplied as standard with each power supply

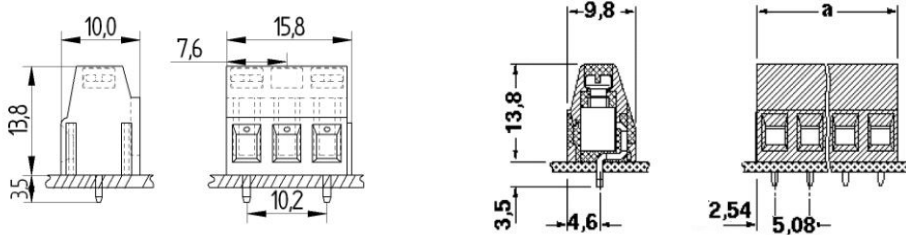

Dimensions in [mm], () = Inch
Tolerances: ±0.5 mm (±0.02)

Wiring

	Description	Wire size	Torque
AC Input	all models: L, N only (2 pin terminal)	AWG 20 – 14 / 0.5 – 2.5 mm ² max.	0.5 Nm
DC Output	6 – 50 W models: single terminal	AWG 20 – 14 / 0.5 – 2.5 mm ² max.	0.5 Nm
DC Output	75 – 90 W models: double terminal	AWG 20 – 14 / 0.5 – 2.5 mm ² max.	0.5 Nm